

All dimensions based on stackup of sheetmetal, subject to variation of 1/2" ( 13 mm)

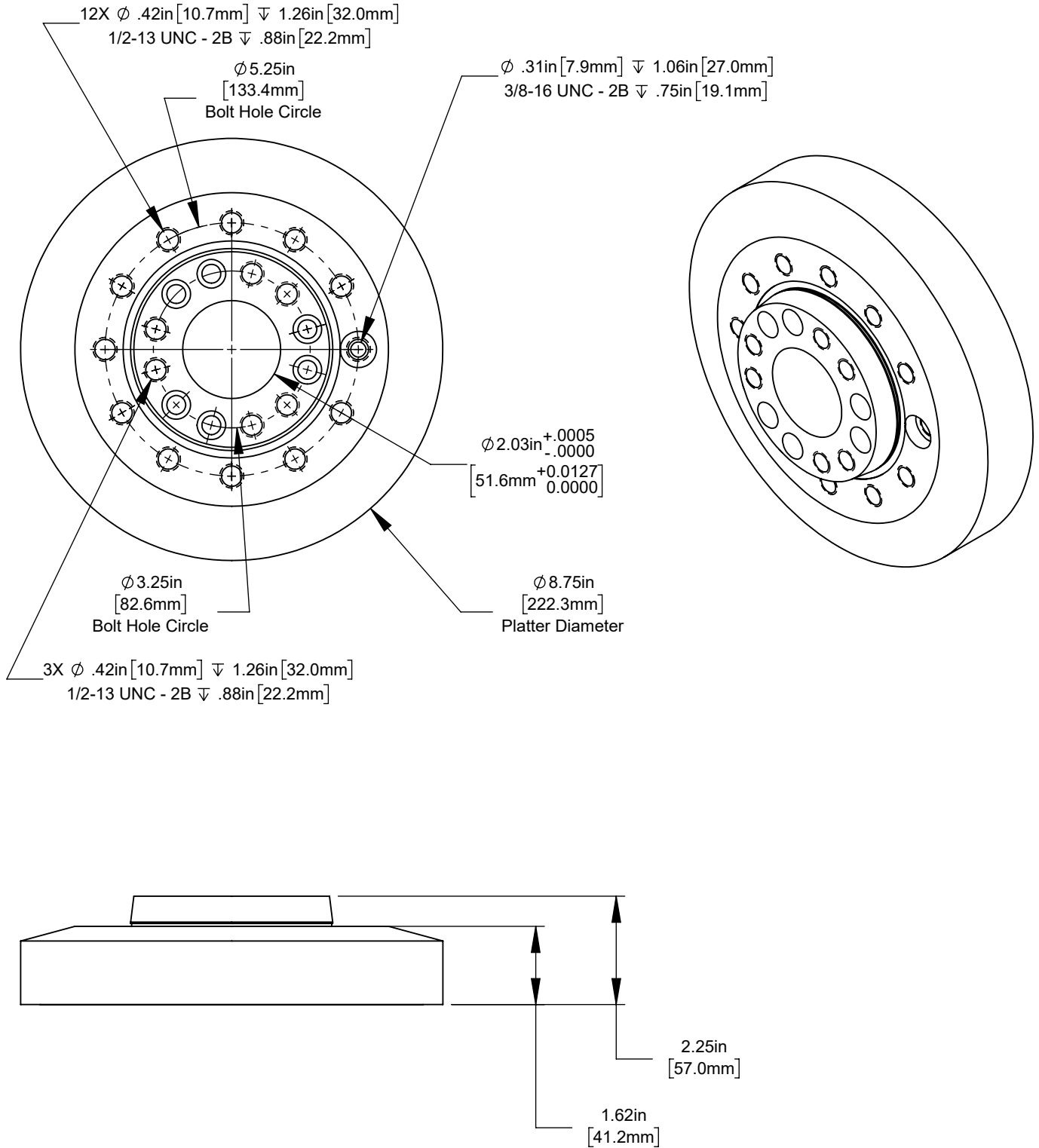

All dimensions based on stackup of sheetmetal, subject to variation of 1/2" ( 13 mm)